

Eclipse ImmersoPak Burners

Model IP004

Version 2

Parameter	Fixed Air (Control Options 1,3,4)			Modulating Air (Control Option 2)		
	Nat Gas	Propane	Butane	Nat Gas	Propane	Butane
High Fire kBtu/hr. (kW) @ 3% O ₂	290 (85)	275 (80)	270 (79)	270 (79)	275 (80)	275 (80)
Low Fire kBtu/Hr. (kW)	30 (9)	20 (6)	20 (6)	60 (18)	40 (12)	30 (9)
High Fire CO (ppm) @ 3% O ₂	<50	<50	<50	<50	<50	<50
Orifice Size (mm)	7.9	6.4	5.8	10	7.9	7.6
Air Pressure @ Max. Input – Air Pressure at burner inlet (Tap "A")	7" w.c. (17.5 mbar)			3" w.c. (7.5 mbar)		
Main Gas Pressure "w.c. (mbar)	Maximum			27.7 (69)		
	Minimum			10 (25)		
	Recommended			15 (37)		
Tube Back Pressure "w.c. (mbar)	.4 (1)			.65 (1.6)		
Weight – less actuator lbs. (kg)	68 (31)					
Blower Type	6" Packaged					
Gas Piping	N.P.T. or B.S.P.*					
Flame Detection	Flame Rod or U.V. Scanner					

* B.S.P. is interface connection only.

- All information is based on laboratory testing with a tube effective length of 32 feet. Different tube sizes and conditions (including backpressure) may affect the data.
- All information is based on standard tube design. Changes in the tube will alter performance and pressures.
- All inputs based upon gross calorific values.
- Plumbing of air and gas will affect accuracy of orifice readings. All information is based on generally acceptable air and gas piping practices.
- For 65% to 80% efficiency at high fire, tube length should be 10 to 23.5 feet long.
- Eclipse reserves the right to change the construction and/or configuration of our products at any time without being obliged to adjust earlier supplies accordingly.

Performance Graphs

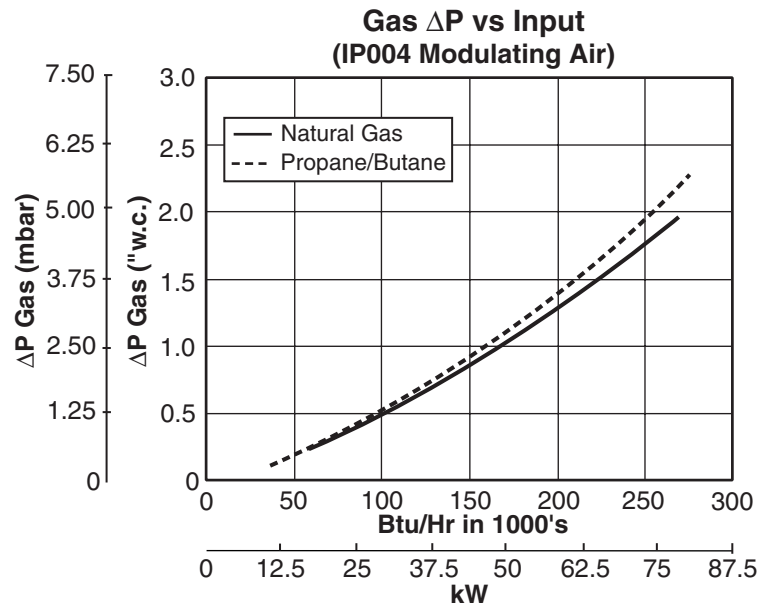
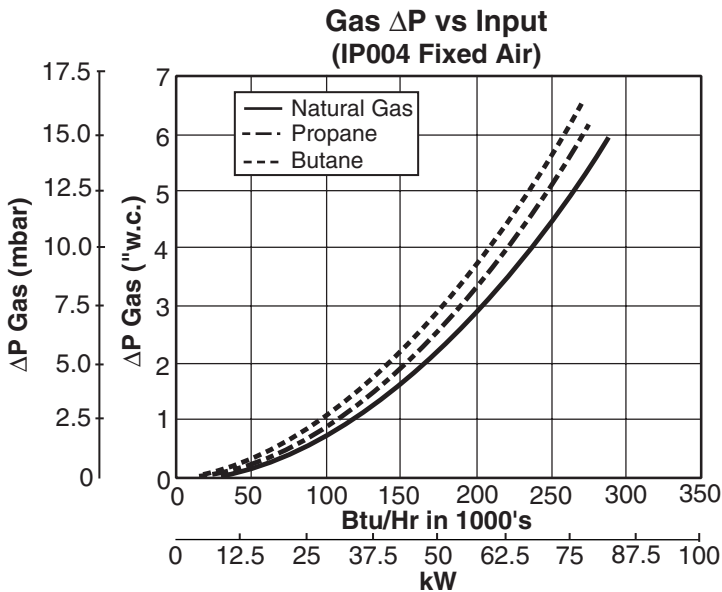
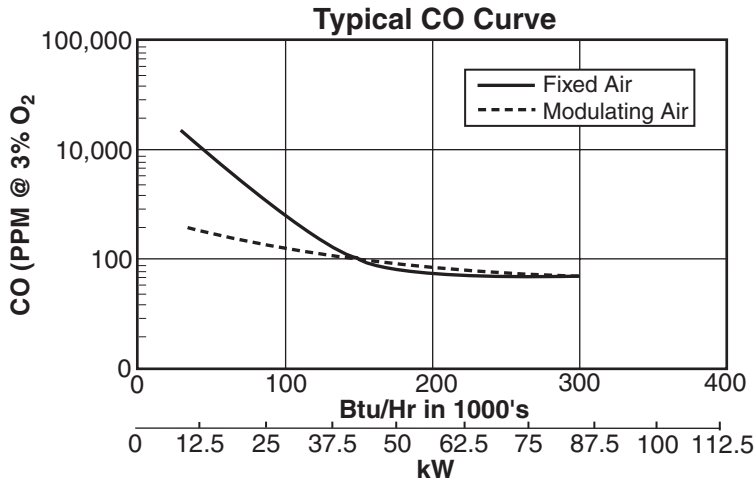
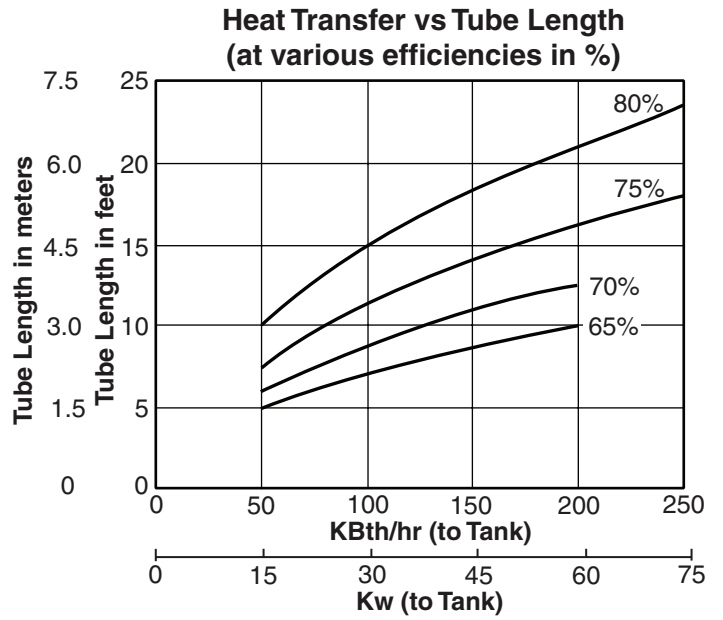
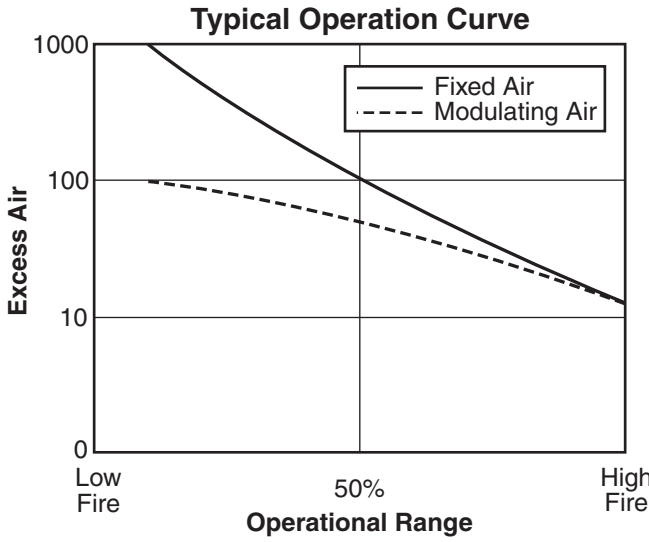

Dimensions & Specifications

Dimensions in mm (inches)

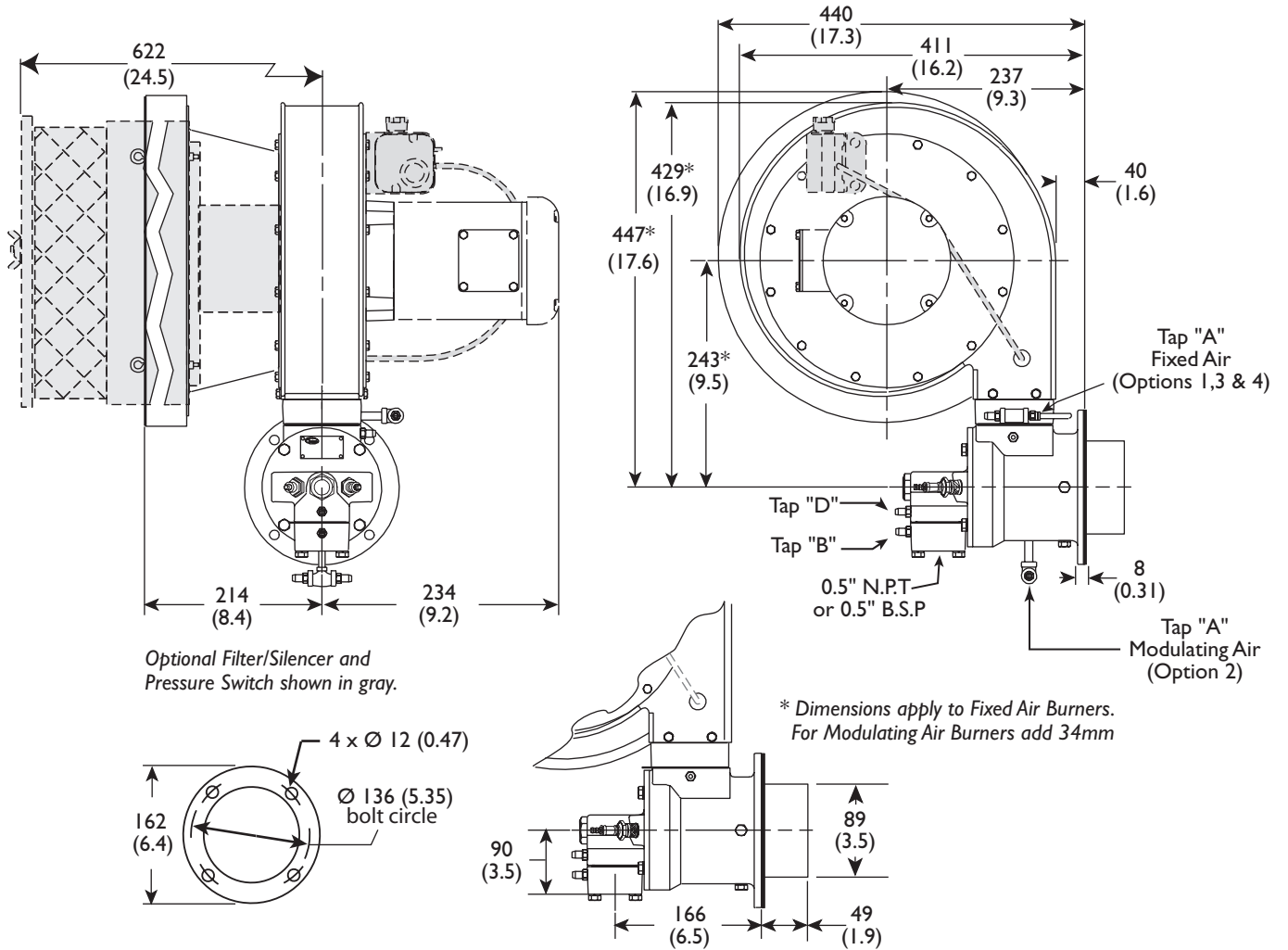

Control Options

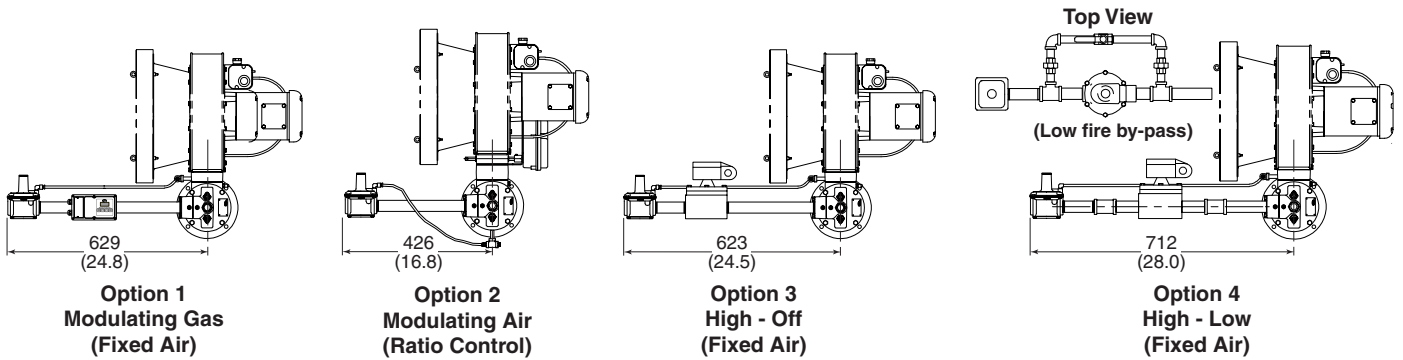

Orientation

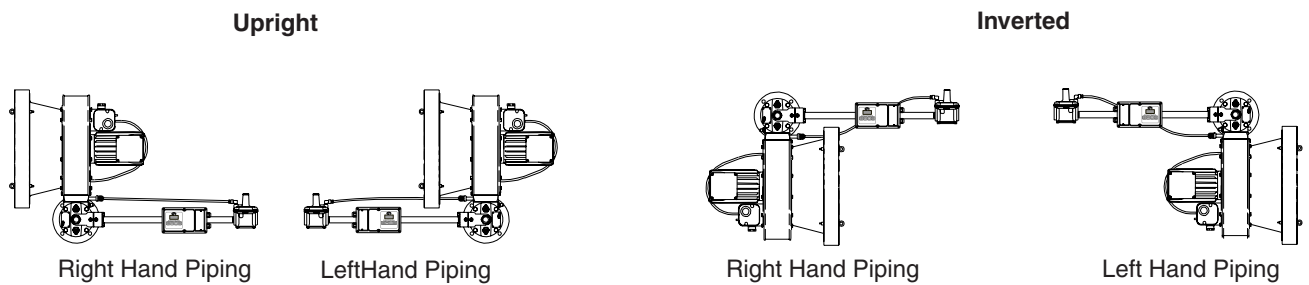



Offered By:

Power Equipment Company
2011 Williamsburg Road
Richmond, Virginia 23231
Phone (804) 236-3800
Fax (804) 236-3882

www.peconet.com